

System Specifications

ROLONOF (HOOK TYPE) CONTAINER
VEHICLE 32/8

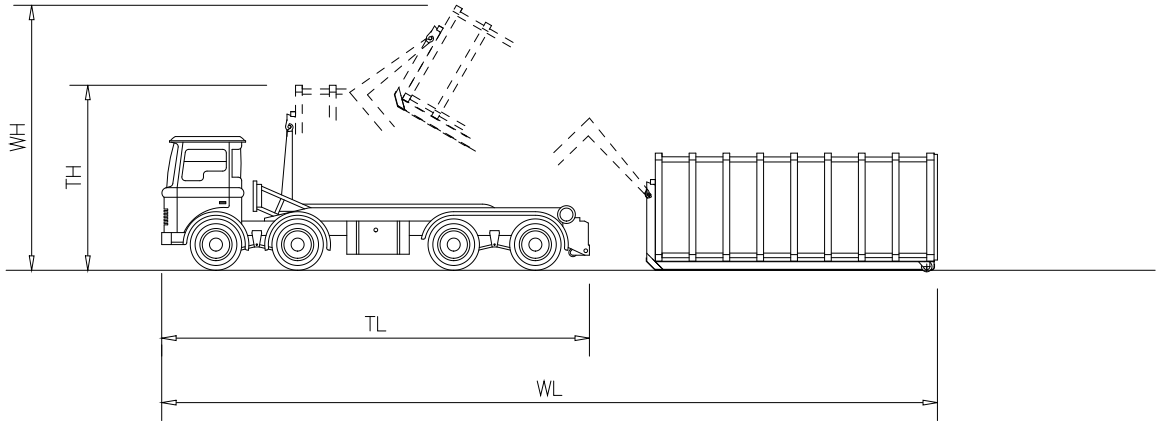

ALL VEHICLE DIMENSIONS ARE APPROXIMATE ACCORDING TO VEHICLE MODEL/CHASSIS HEIGHT

		Travel Length	Working Length	Travel Height	Working Height	Turning Circle	Payload
		TL	WL	TH	WH	(kerb to kerb)	
32 TON GVW (4 axles)	Metres (max)	9.3	16.15	4.0	5.6	21.5	19500 kg
	Feet (max)	30'-6"	53'-0"	13'-1"	18'-4"	70'-6"	19.2 T

} COMPACTION CONTAINER ONLY

(ADJUST CHARTED DIMENSIONS WL, TH & WH FOR ULTIMATE)

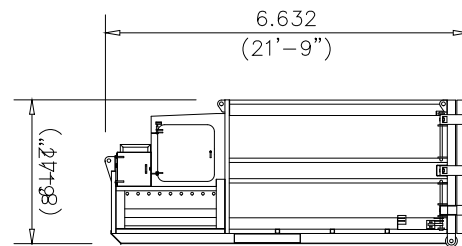

Ultimate - 32yd Demountable
Compactor

	Dimension 'A'	
	Metres	Feet
22.9cu.m (30cu.yd)	2.3	7'-6"
26.8cu.m (35cu.yd)	2.5	8'-2"
30.6cu.m (40cu.yd)	2.8	9'-2"

All containers are 2.5m (8'-2") wide

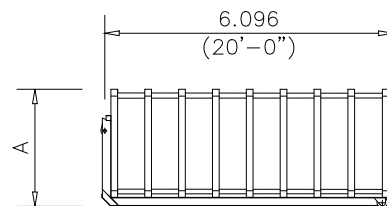

22.9-30.6cu.m (30-40cu.yd)
Compaction Container

G: \DRGS\MISC\PUBSHT2

		SCALE N.T.S.	DRAWN LD/CAD	 THETFORD INTERNATIONAL LIMITED RYMER POINT BURY RD THETFORD NORFOLK IP24 2PN TEL: THETFORD (01842) 890500 FAX: (01842) 890077
01	GENERAL UPDATE	LD/15.02.08	CHKD	
MOD	REVISION	BY/DATE	APPD	DRAWING TITLE ROLONOF (HOOK TYPE) CONTAINER VEHICLE 32/8 STANDARD
			DATE 15.02.08	

THIS DRAWING IS ISSUED ON CONDITION THAT IT IS NOT COPIED, REPRODUCED OR DISCLOSED TO A THIRD PARTY WITHOUT THE WRITTEN CONSENT OF THE THETFORD INTERNATIONAL LIMITED